

SALES DRAWING

SALES DRAWING

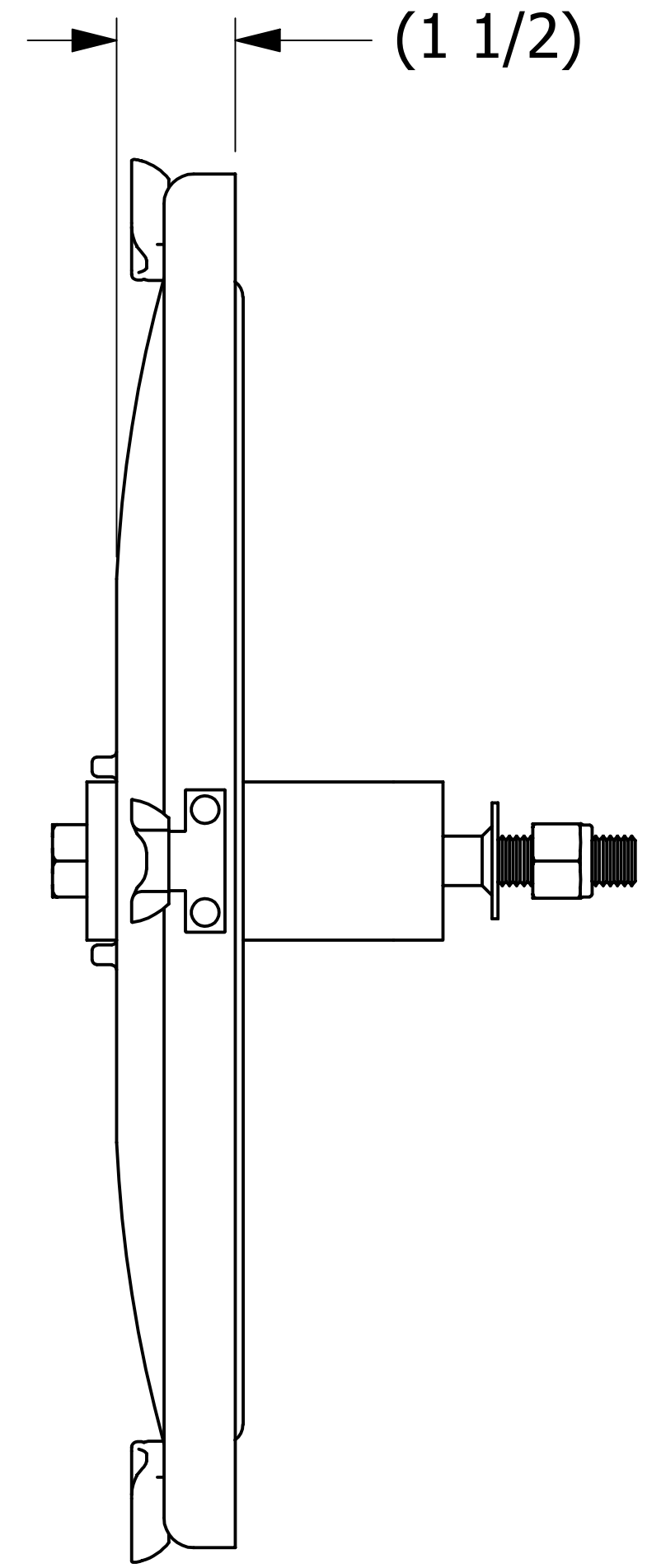
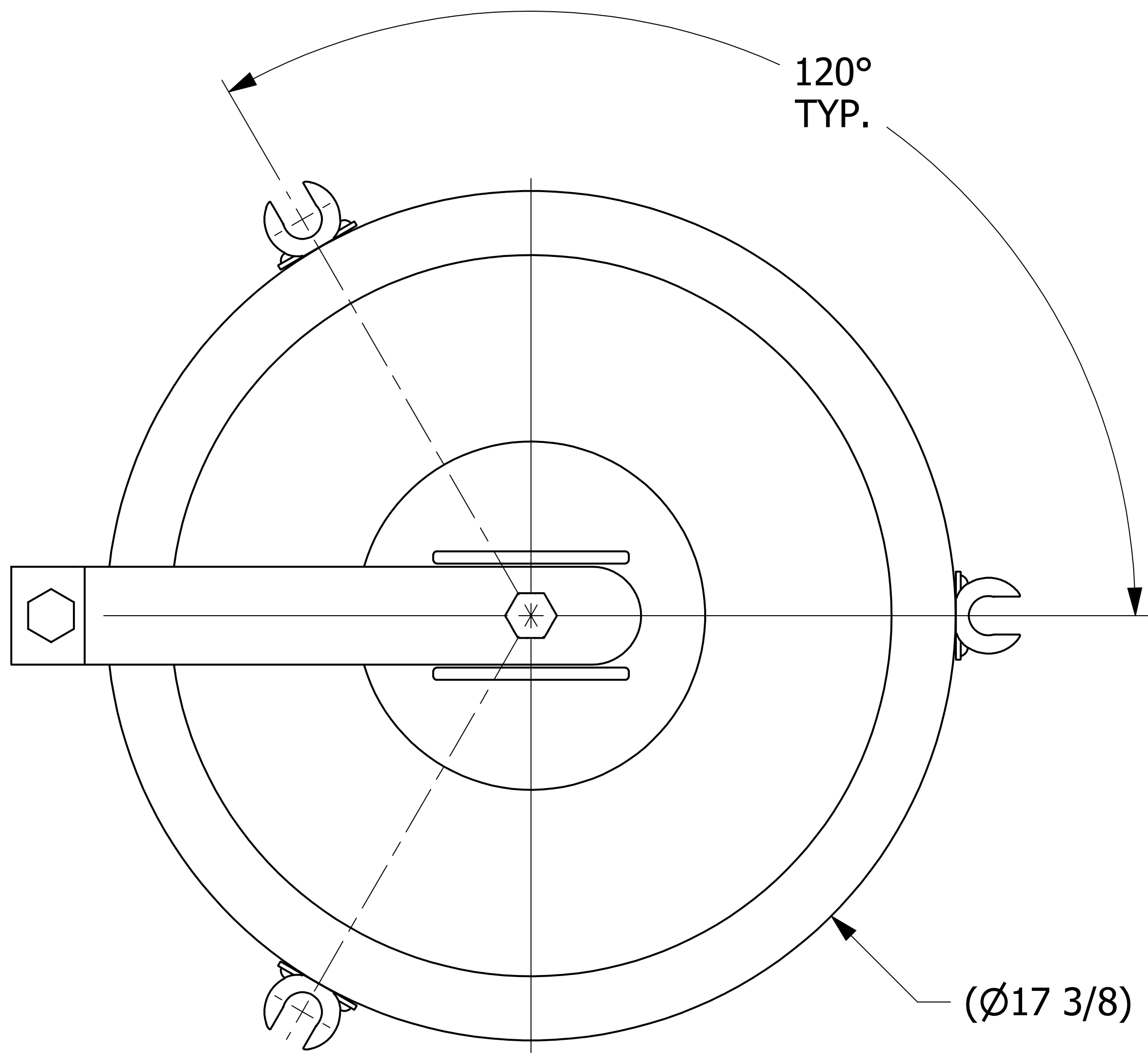

NOTE:  
GASKET IS FOAM NEOPRENE.

|     |     |          |   |
|-----|-----|----------|---|
| B   | RJP | 10-20-15 | REPLACED D40088, SV58SN, & A40190 WITH C40744 |
| A   | RJP | 9-22-15  | RELEASED FOR PRODUCTION                       |
| REV | BY  | DATE     | DESCRIPTION                                   |

|   |                             |            |
|---|-----------------------------|------------|
| UNLESS OTHERWISE SPECIFIED<br>DIMENSIONAL TOLERANCES<br>FRACTIONAL: $\pm 1/16$<br>X.XX: $\pm .03$<br>X.XXX: $\pm .015$<br>ANGULAR: $\pm 1^\circ$<br>DEBURR ALL SHARP EDGES.<br>ALL MACHINED SURFACES TO<br>HAVE A 125 RMS FINISH<br>UNLESS NOTED OTHERWISE.<br>THIRD ANGLE PROJECTION | DRAWN BY:                   | RJP        |
|   | CHECKED BY:                 | CHL        |
|   | PROTOTYPE BY:               | RJP        |
|   | PROTOTYPE DATE:             | 10/20/2014 |
|   | APPROVED FOR PRODUCTION BY: | EJF        |
|   | PRODUCTION DATE:            | 9/22/2015  |

|                                      |                              |                           |
|--------------------------------------|------------------------------|---------------------------|
| <b>SALCO PRODUCTS, INC.</b>          |                              |                           |
| PART NAME:<br><b>VALVE COVER 16"</b> |                              |                           |
| MATERIAL:<br><b>ABS</b>              | PROJECT #:<br><b>R140912</b> | SHEET #:<br><b>1 OF 1</b> |
| DRAWING #:<br><b>D40208</b>          | PART #:<br><b>PHC16CBV2A</b> | SCALE:<br><b>1:2</b>      |

THIS PRINT, PROPERTY OF SALCO PRODUCTS INC. CONTAINS PROPRIETARY INFORMATION AND MUST NOT BE COPIED, REPRODUCED, OR USED DETRIMENTALLY TO OUR INTEREST.